

2 - Hood/Tank

CODE	DESCRIPTION
120348	MAGN.SWITCH (N.O.)
160811	WASHER F2 18X8.5X1 ALGOF
160907	CONNECTION FOR TABLES C95-155
180642	GUIDE
190637	GUIDE FOR DOOR "C"
190638	ROLLER FOR "C" DOOR GUIDE
190806	MAGNET HOUSING
200925	GASKET
200957	GASKET
200964	GASKET 618X14 SP.2
260113	STAINL.ST.TE SCREW 8X20 A2 UNI
260202	SCREW TCP 3X16
260219	STAINL.ST TCP SCREW 6X35 A2 UN
260224	TB-SCREW 6X15 B23-10-11-12
260312	SCREW TSP 4X16
260329	VITE M5X12 SPEC.ZIGR.SOTTOTEST
260404	STAINLESS STEEL NUTS D6 UNI 55
260418	SELF-LOCKING NUT M4
260502	S/S FLAT WASHER D.4
260504	ST/ST FLAT WASHER D6
260505	STAINL.STEEL FLAT WASHER D8
260512	ST/ST GROWER WASHER D6
260513	GROWER WASHER D8
260538	WASHER 18X6X1,5 ST/ST
260543	WASHER D.6 ST/ST
320534	LOWER FRAME
324016	SWITCH BRACKET
331835	BRACKET F.MAGNET C165
332424	SQUADRETTA SOST.TUBO PRESS.C
342257	TANK
342497	HOOD
342498	INSULATED HOOD
351421	LEFT PANEL
351422	RIGHT PANEL
351767	FRONT PANEL
351899	FRONT PANEL C1000-1300
361069	BACK FRAME
390182	BACK PANEL
411002	PERMANENT MAGNET 24X12
440211	LEGS
463173	DOX SYSTEM C1000E
463174	DOX SYSTEM C1300E
530238	RACK SUPPORT C-SERIES

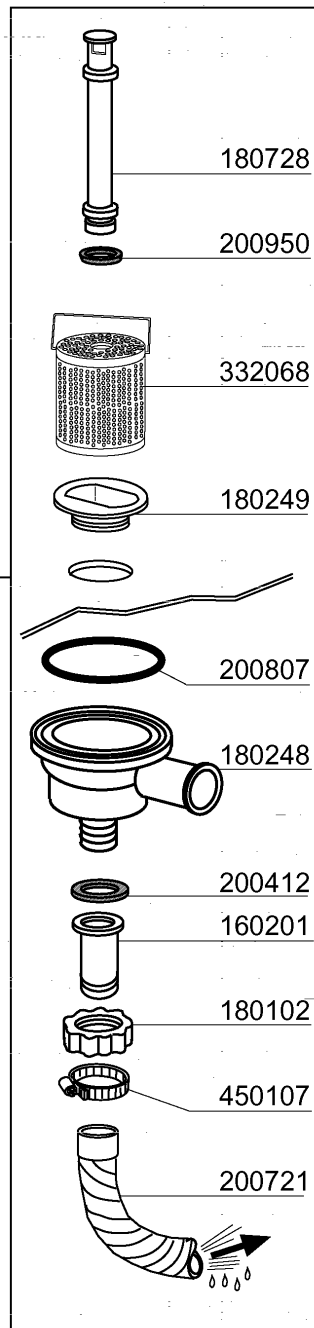
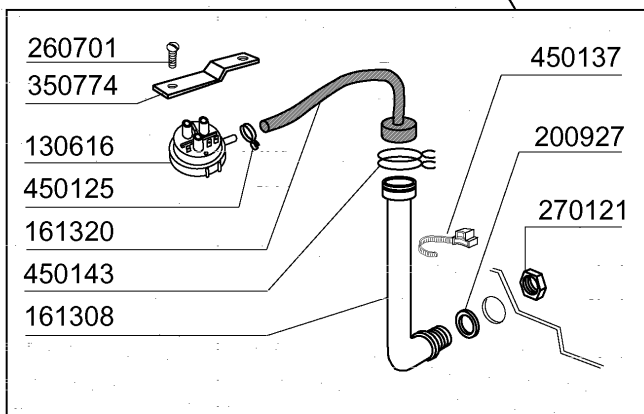
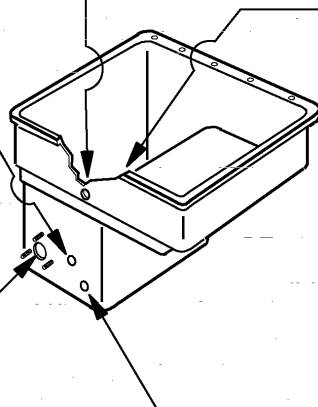
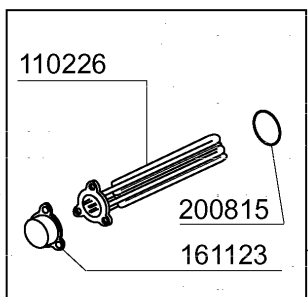
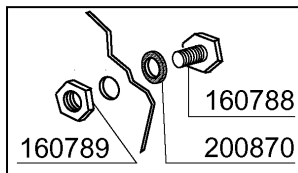
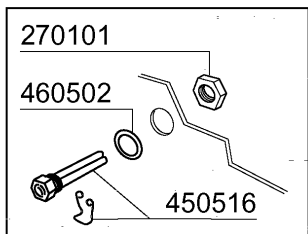
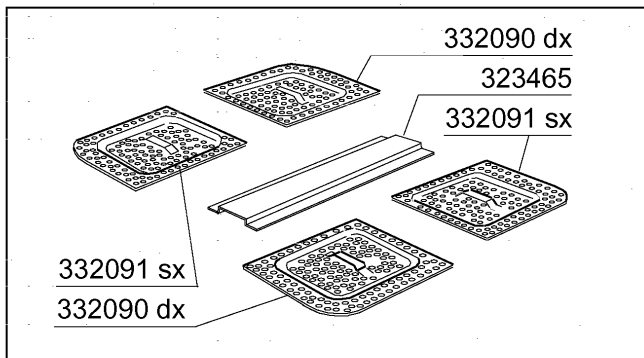

02 - 2004 | S. AG.

3 - Tank

CODE	DESCRIPTION
110226	HEAT. ELEMENT 3000W 230/400V
130616	PRESSURE SWITCH 190/80 FOR C95
160201	ELBOW F.TANK INLET MOPLN
160788	PLUG
160789	NUT
161123	HEAT.ELEMENT COVER H42 SNL
161308	AIR CHAMBER C95-155
161320	HOSE FOR AIR CHAMBER
180102	DRAIN PIPE NUT 1"1/2 F45-55
180248	SUCTION TANK
180249	NUT
180728	OVERFLOW PIPE
200412	GASKET DRAIN 11/2" 45X33X3
200721	DRAIN HOSE 28X35 2MT.
200807	O-RING 3,53 X 110,72
200815	O-RING F. HEAT.ELEM.
200870	GASKET 18X10X2
200927	GASKET FOR AIR TRAP
200950	VITON GASKET
260701	SCREW 3,5X9,5
270101	HEXAGON LOCK NUT 1/2"
270121	NUT FOR AIR TRAP
323465	STRAINERS SUPPORT
332068	STRAINER
332090	RIGHT STRAINER
332091	TANK LEFT STRAINER
350774	BRACKET
450107	CLAMP FE ZN 38-50 H=12,2
450125	ELASTIC CLAMP D. 10,4X9,8
450137	COLLAR CONNECTION WITH BASE 31
450143	CLAMP D.39,7 X 37,7
450516	THERMOSTAT SHIELD FOR 2 TERMOS
460502	GASKET 30X21X2

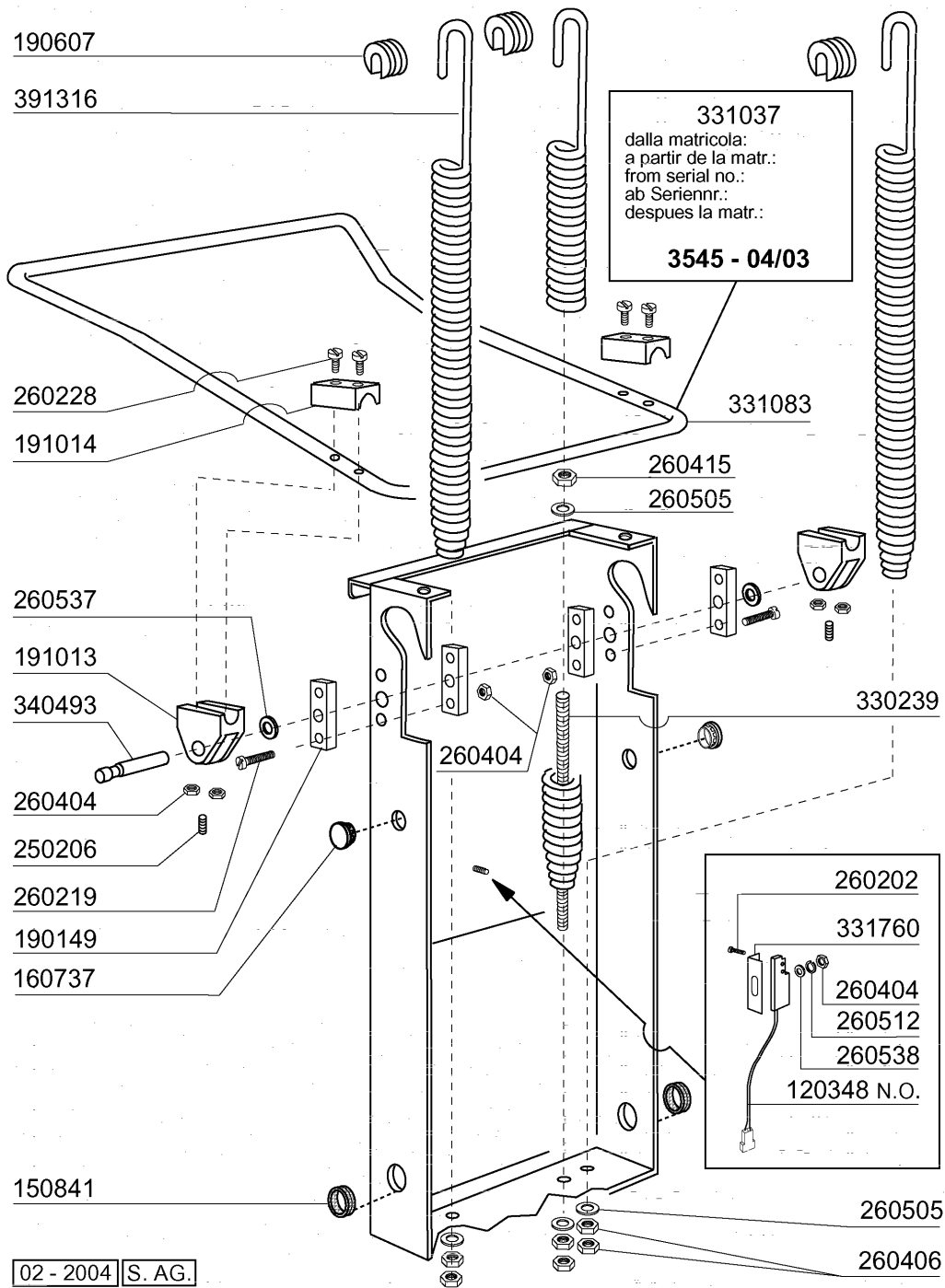

4 - Handle

CODE	DESCRIPTION
120348	MAGN.SWITCH (N.O.)
150841	CABLE HOLDER
160737	PLUG HEYCO D.34,9
190149	REINFORCEMENT FOR HANDLE SUPP.
190607	HANDLE BUSH C30-70
191013	HINGE F. SUPPORT C30-C70
191014	FLANGE F. HANDLE C30-70
250206	GRUB SCREW D.6
260202	SCREW TCP 3X16
260219	STAINL.ST TCP SCREW 6X35 A2 UN
260228	STAINL.ST SPECIAL SCREW 6X42 3
260404	STAINLESS STEEL NUTS D6 UNI 55
260406	NUT 8MA
260415	STAINLESS STEEL SELF-LOCKING N
260505	STAINL.STEEL FLAT WASHER D8
260512	ST/ST GROWER WASHER D6
260537	STAINL.STEEL FLAT WASHER D13X2
260538	WASHER 18X6X1,5 ST/ST
330239	ROD
331037	HANDLE C95-155-165 ISOLATED
331083	HANDLE
331760	BRACKET
340493	PIN F. HINGE C30
391316	SPRING FOR HANDLE C85/140-G75

5 - Wash/Rinse column

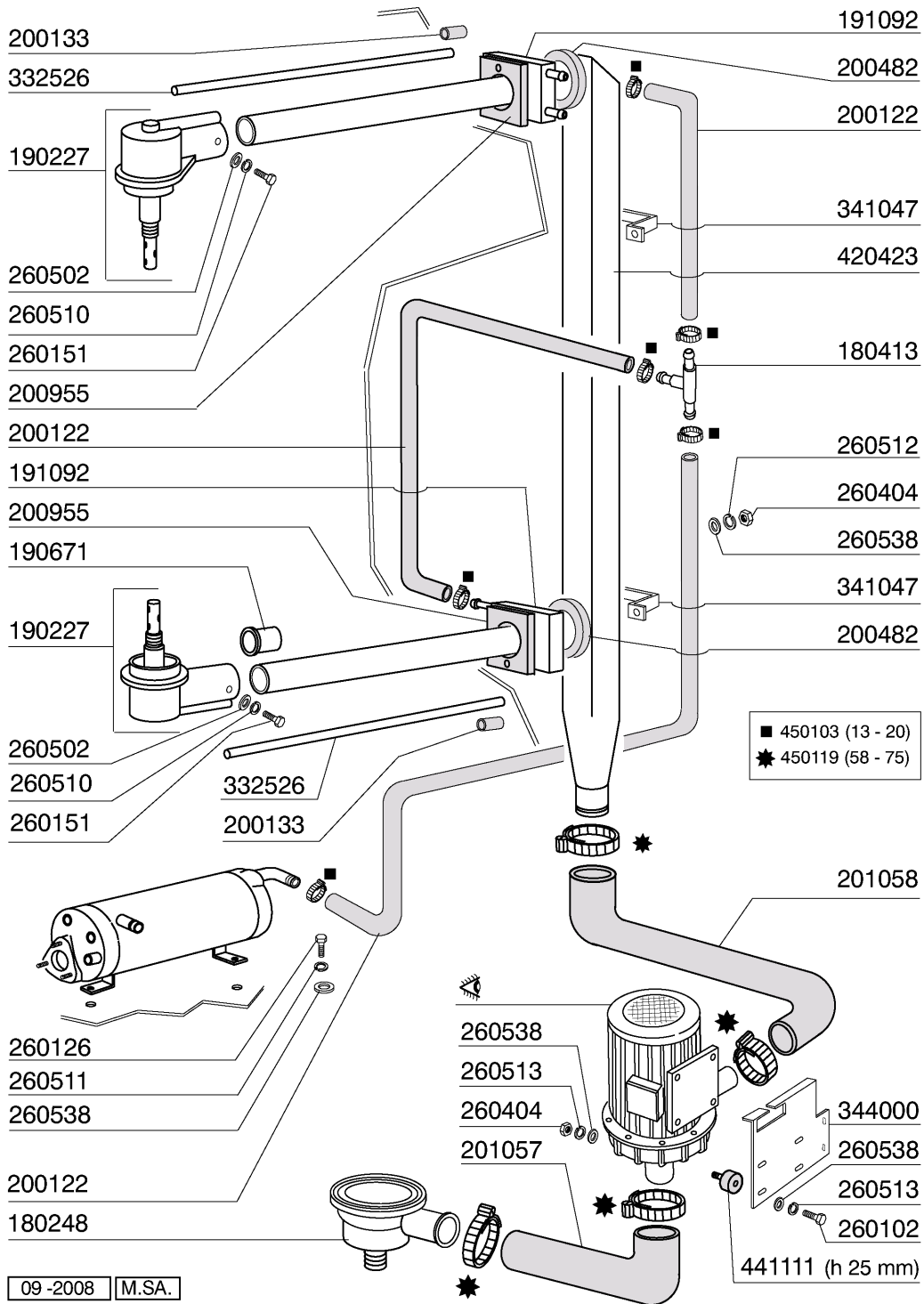

5 - Wash/Rinse column

CODE	DESCRIPTION
180248	SUCTION TANK
180413	TEE NIPPLE D.11,5 - RINSE ASSE
190227	ARM SUPPORT
190671	BUSH
191092	RINSE COLLECTOR
200122	HOSE 11X19
200133	HOSE 7X11
200482	GASKET 60X54 RAMP C140
200955	GASKET
201057	WASH PUMP INLET HOSE
201058	OUTLET HOSE
260102	SCREW TE 6X10
260126	SCREW TE 5X12
260151	SCREW TE 4X12
260404	STAINLESS STEEL NUTS D6 UNI 55
260502	S/S FLAT WASHER D.4
260510	GROWER WASHER D.4
260511	GROWER WASHER D.5
260512	ST/ST GROWER WASHER D6
260513	GROWER WASHER D8
260538	WASHER 18X6X1,5 ST/ST
332526	RINSE HOSE
341047	U-BOLT FOR WASH.RAMP
344000	PUMP SUPPORT
420423	WASH RAMP C/LC
441111	PUMP FEET 25X25XM6
450103	CLAMP FE ZN. 13-20 H=9
450119	CLAMP FE ZN. 58-75 H=12,2

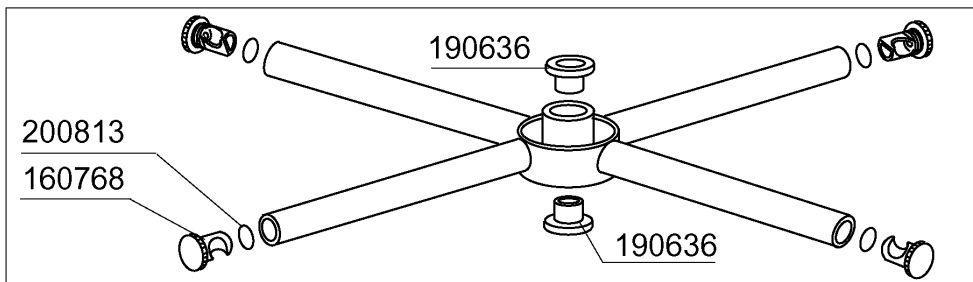
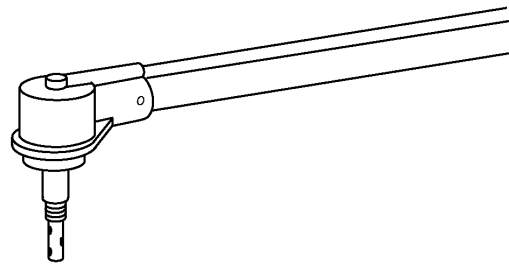

420535

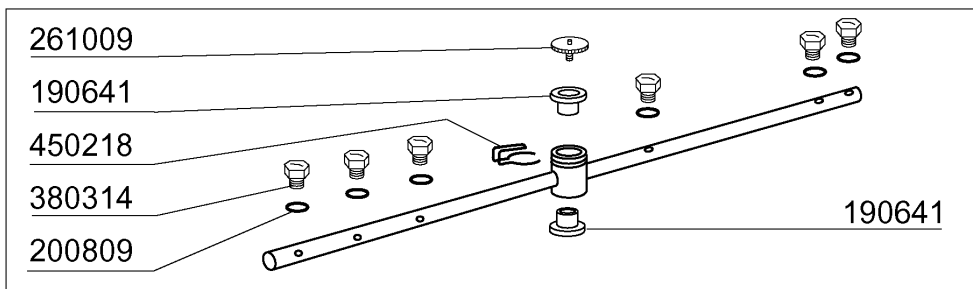
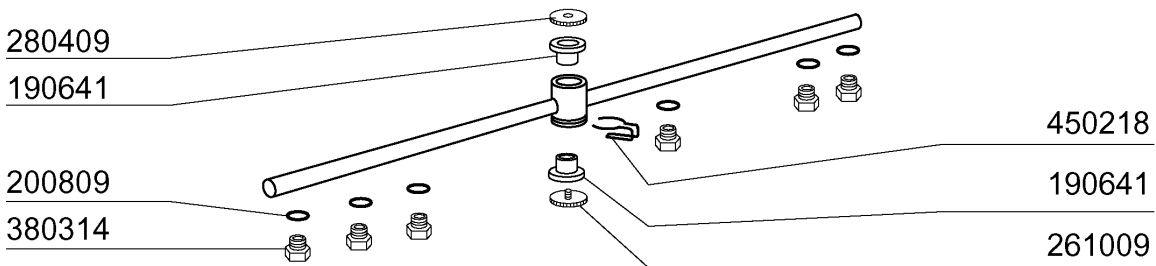

430316

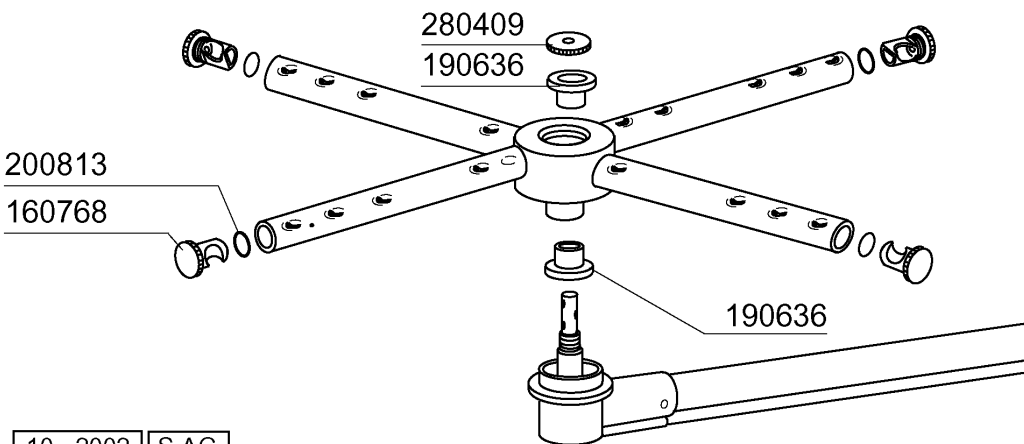

6 - Wash arm

CODE	DESCRIPTION
160768	PLUG FOR "C95-155" WASH ARM
190636	BUSH FOR C95-155-165 WASH ARM
190641	BUSH FOR C95-155-165 RINSE ARM
200809	OR GASKET 1,78X8,73X12,29
200813	OR GASKET 2,21X16,36X20,78
261009	RETAIN.SCREW FOR WASH-RINSE AR
280409	RETAIN.LOCK NUT CENTR.CROSS C1
380314	RINSE JETS 801/HR
420535	WASH ARM C1300-C155
430316	RINSE ARM FOR C95-C155-C165
450218	SPRING F.RINSE ARM RETAIN.SCRE

7 - Rinse assembly

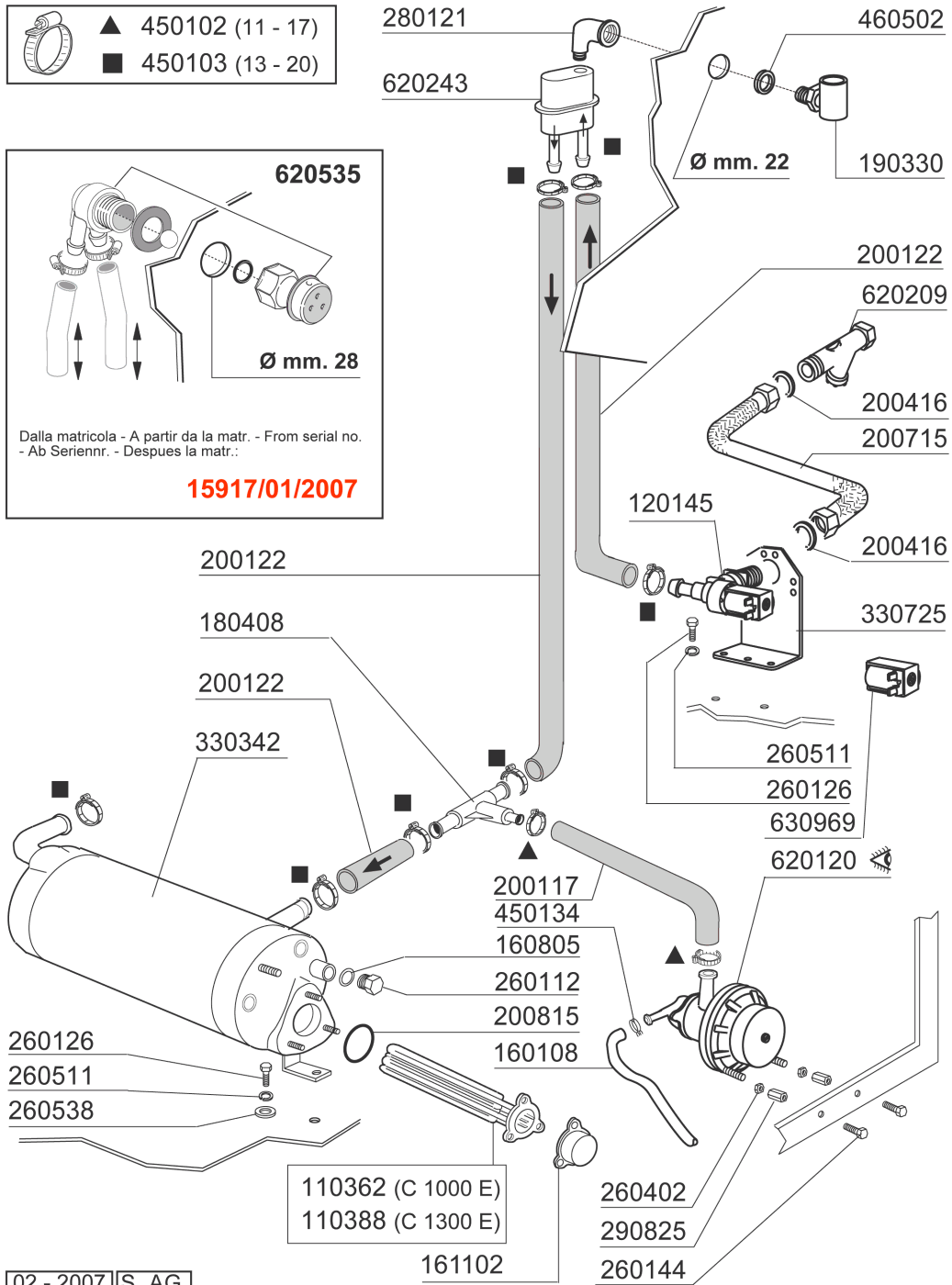

7 - Rinse assembly

CODE	DESCRIPTION
110362	HEAT.ELEMENT 9000W 220/380V
110388	HEAT.ELEMENT 10000W 230/400V
120145	SOLENOID VALVE 12 LT 1 WAY
160108	INJECT.INLET HOSE D.8X5
160805	GASKET D.8
161102	ELEMENT COVER MOPL.
180408	TEE-NIPPLE F.INJECT.W/CENTR.RE
190330	TEE FOR VAACUM BREAKER
200117	RUBBER HOSE 7X16
200122	HOSE 11X19
200416	GASKET D. 3/4"
200715	HOSE WATER INLET 2M STAINL.ST
200815	O-RING F. HEAT.ELEM.
260112	STAINLESS STEEL TE-SCREW 8X16
260126	SCREW TE 5X12
260144	SCREW TE 4X6
260402	STAINLESS STEEL NUT D4 UNI 55
260511	GROWER WASHER D.5
260538	WASHER 18X6X1,5 ST/ST
280121	ELL FOR VAACUM BREAKER
290825	SPACER
330342	BOILER C95-C155-C165
330725	STANDARD BRACKET F.SOLEN.VALV
450102	CLAMP FE ZN 11-17 H=9
450103	CLAMP FE ZN. 13-20 H=9
450134	ELASTIC HOSE CLIP D.9,3/8,8
460502	GASKET 30X21X2
620120	RINSE AID INJECTOR
620209	INLET WATER FILTER
620243	VACUUM BREAKER (WITHOUT KIT)
620535	VACUUM BREAKER
630969	COIL S4216 220/50HZ

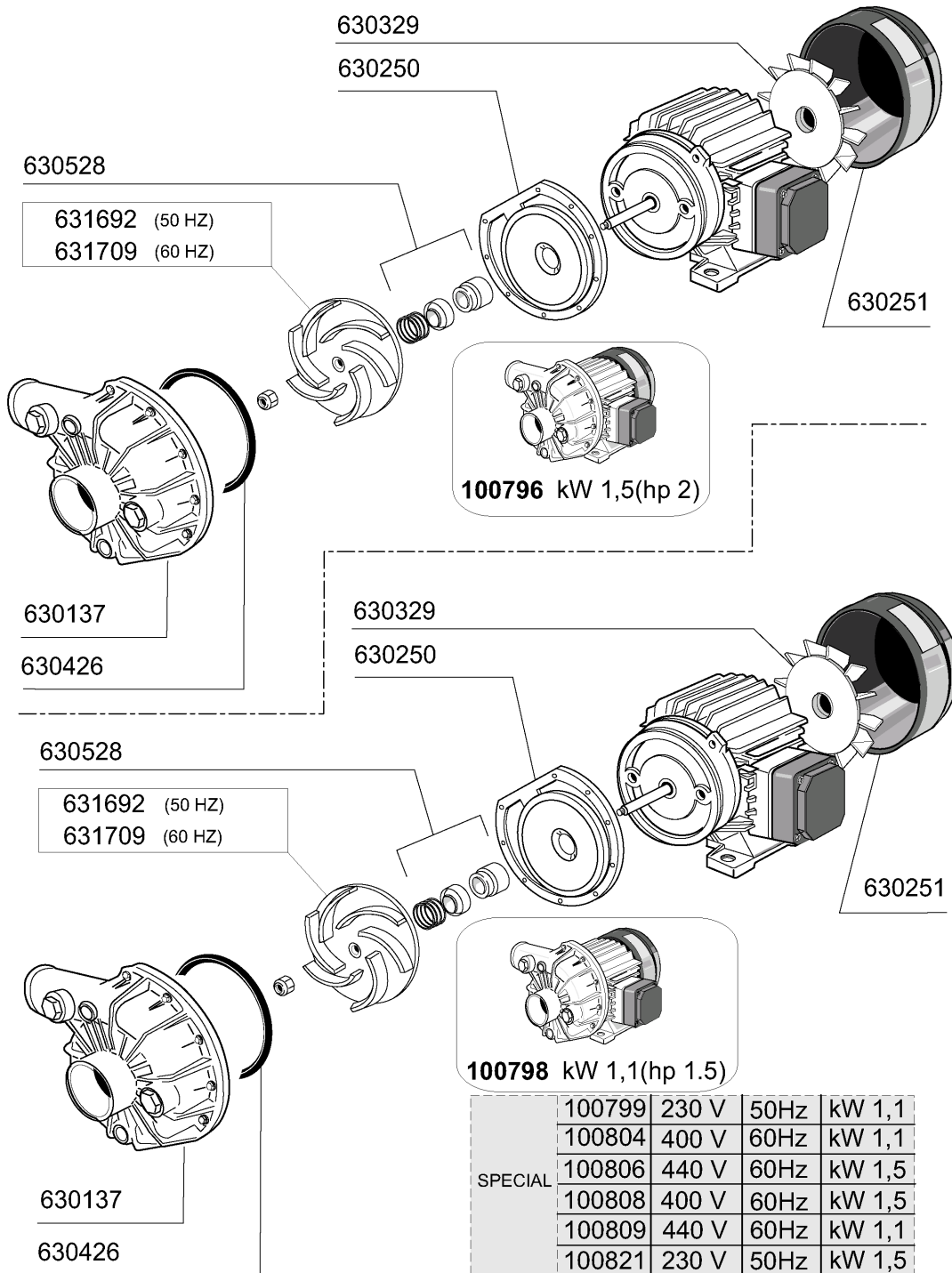

05 - 2009 | M.SA.

8 - Wash pump

CODE	DESCRIPTION
100796	PUMP 2HP 400/3/50HZ LGB
100798	PUMP 1,5HP LGB
100799	PUMP HP1,5-230/50
100804	PUMP 1,5HP 220/3/60
100806	PUMP 2HP 440V/3 60HZ
100808	PUMP HP 2 380/3/60
100809	PUMP HP 1,5 440/3/60
100821	PUMP HP 2 230/1/50
630137	PUMP VOLUTE LGB ZF800DX
630250	BACK PLATE PUMP ZF650/800
630251	FAN HOUSING ZF650/800
630329	PUMP FAN IMPELLOR ZF650/800
630426	GASKET LGB ZF800
630528	SEAL LGB ZF800 2HP
631692	IMPELLER PUMP ZF650/800
631709	PUMP IMPELLER ZF800 60HZ

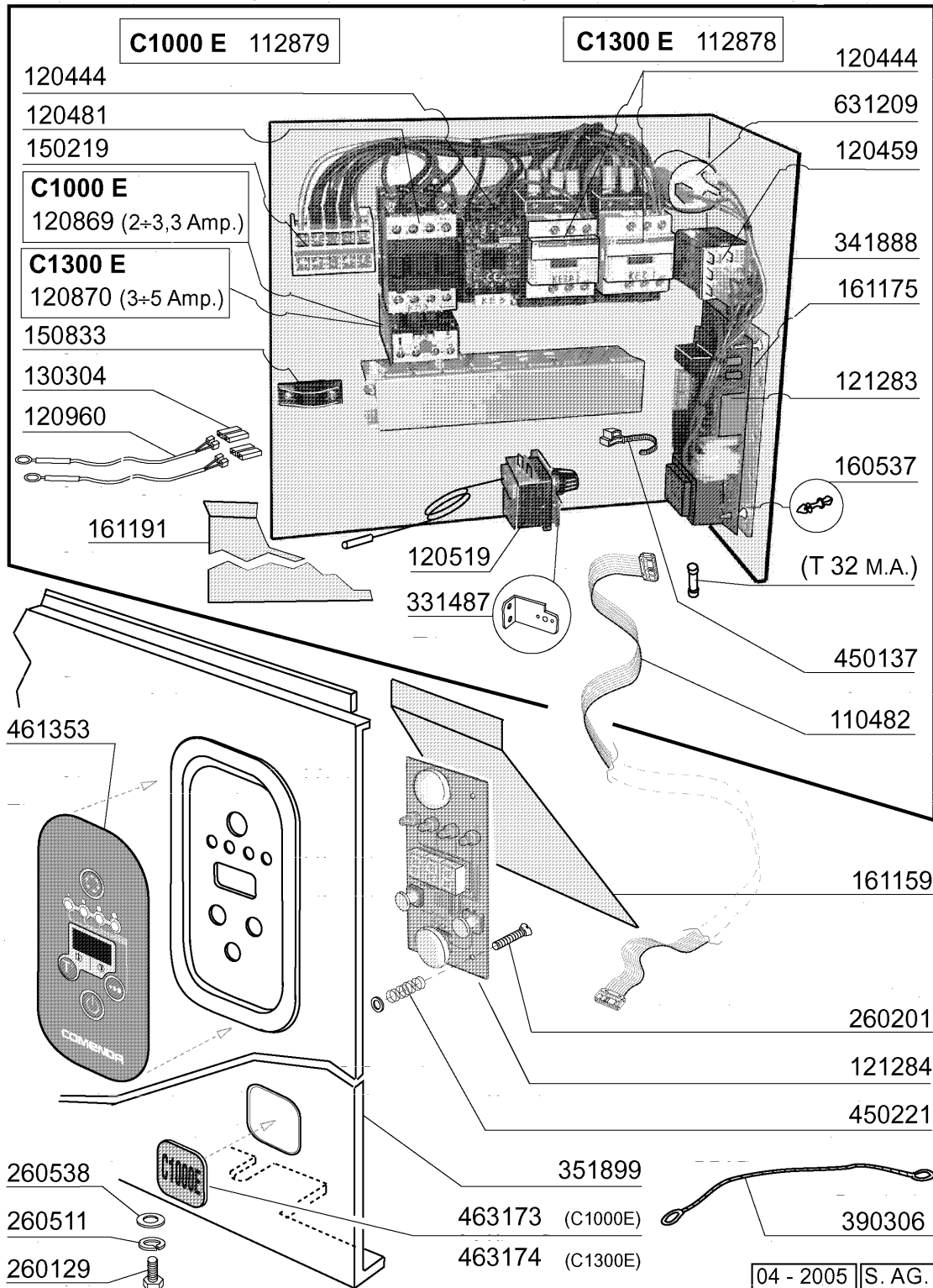

9 - Control panel

CODE	DESCRIPTION
110482	CABLE FOR PCB FC-C-GE
112878	WIRING
112879	WIRING
120444	CONTACTOR 9A 220V 50HZ
120459	AUXIL.RELE 16A 220V
120481	CONTACTOR 9A-230V 50/60HZ
120519	SECURITY THERMOSTAT 95-125Ø
120869	OVERLOAD RELAY 2/3,3
120870	OVERLOAD RELAY 3/5
120960	PROBE C-G
121283	ELECTRONIC PANEL "C-GE"
121284	ELECTRONIC CONTROL PANEL C-GE
130304	TERMINAL BLOCK
150219	TERMINAL BLOCK 5P MMQ165VD26
150833	CABLE HOLDER BC/BR
160537	ELECTRONIC CARD SPACER
161159	PROTECT. COMMANDS SWITCHBOARD
161175	PROTECTION
161191	CONTROL BOX COVER
260129	SCREW TE M 5X20
260201	SCREW TCP 3X10
260511	GROWER WASHER D.5
260538	WASHER 18X6X1,5 ST/ST
331487	BRACKET FOR 1 THERMOSTAT
341888	CONTROL BOX SUPPORT
351899	FRONT PANEL C1000-1300
390306	CABLE
450137	COLLAR CONNECTION WITH BASE 31
450221	SPRING FOR ELECTRONIC TIMER
461353	PLATE C-GE ELECTRONIC
463173	DOX SYSTEM C1000E
463174	DOX SYSTEM C1300E
631209	ANTI-NOISE FILTER

10 - Rinse aid injector

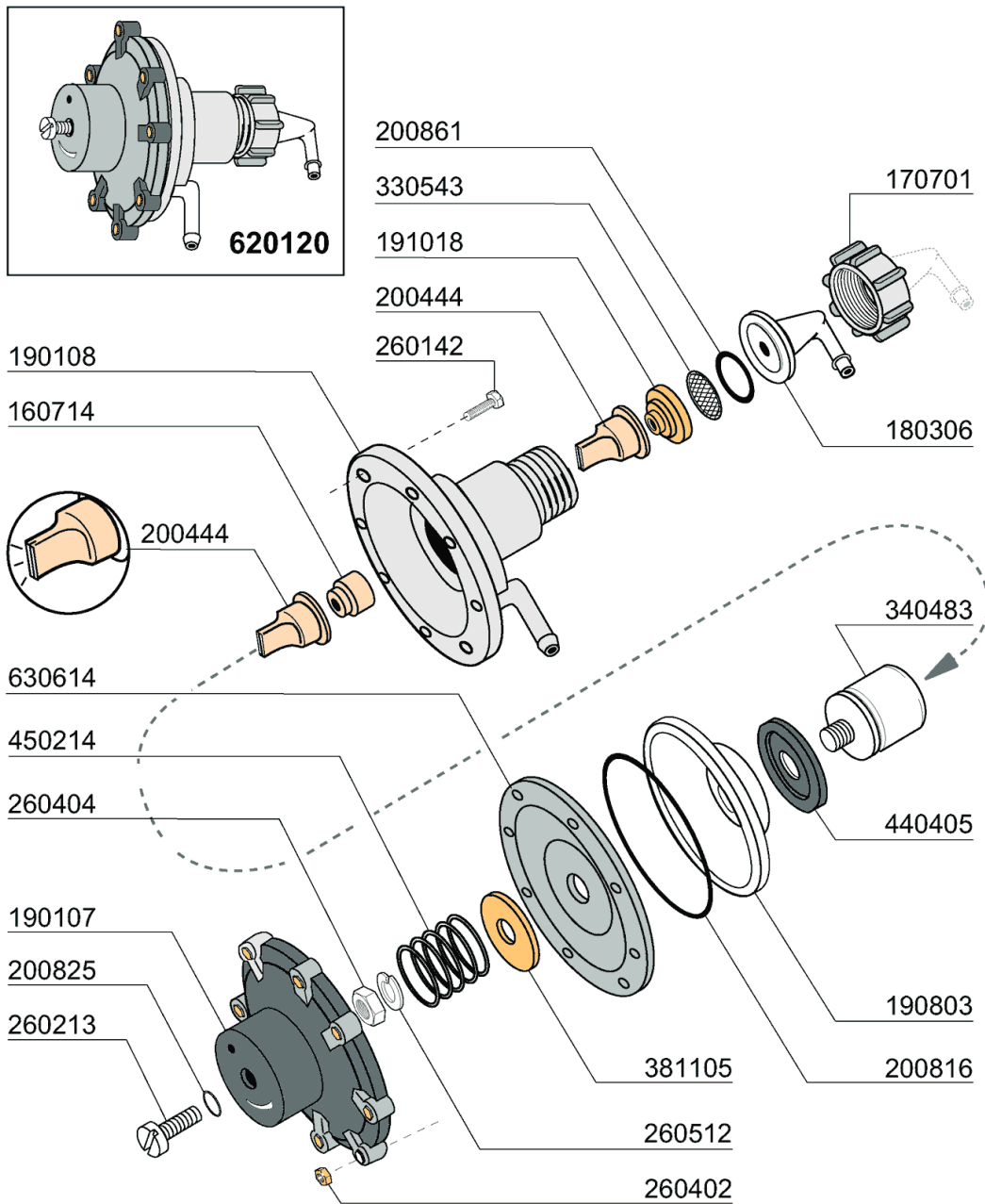

09 - 2007 | S. AG.

10 - Rinse aid injector

CODE	DESCRIPTION
160714	PLUG FOR RINSE AID INJECTOR MO
170701	LOCK NUT 1/2" F.INJECTOR
180306	NIPPLE F.RINSE AID INJECTOR
190107	COVER FOR RINSE AID DISPENSER
190108	VOLUTE FOR RINSE AID DISPENSER
190803	GASKET SUPPORT RING F.INJECT
191018	FILTER SUPPORT RINSE AID INJEC
200444	SUCTION VALVE RINSE INJECTOR
200816	O-RING 2,5X59,2X64,2 RINSE INJ
200825	O-RING 3X5X11 RINSE INJECTOR
200861	O-RING 14X18X2
260142	SCREW TE 4X16
260213	SCREW TCP 5X25
260402	STAINLESS STEEL NUT D4 UNI 55
260404	STAINLESS STEEL NUTS D6 UNI 55
260512	ST/ST GROWER WASHER D6
330543	FILTER RINSE AID INJECTOR D.17
340483	PISTON FOR RINSE AID DISPENSER
381105	DIAPHRAGME DISC
440405	GASKET FOR RINSE AID INJ.
450214	SPRING RINSE AID INJECTOR
620120	RINSE AID INJECTOR
630614	DIAPHRAGM RINSE INJECTOR

620511



- 450114 (22 - 32)
- 450105 (26 - 38)

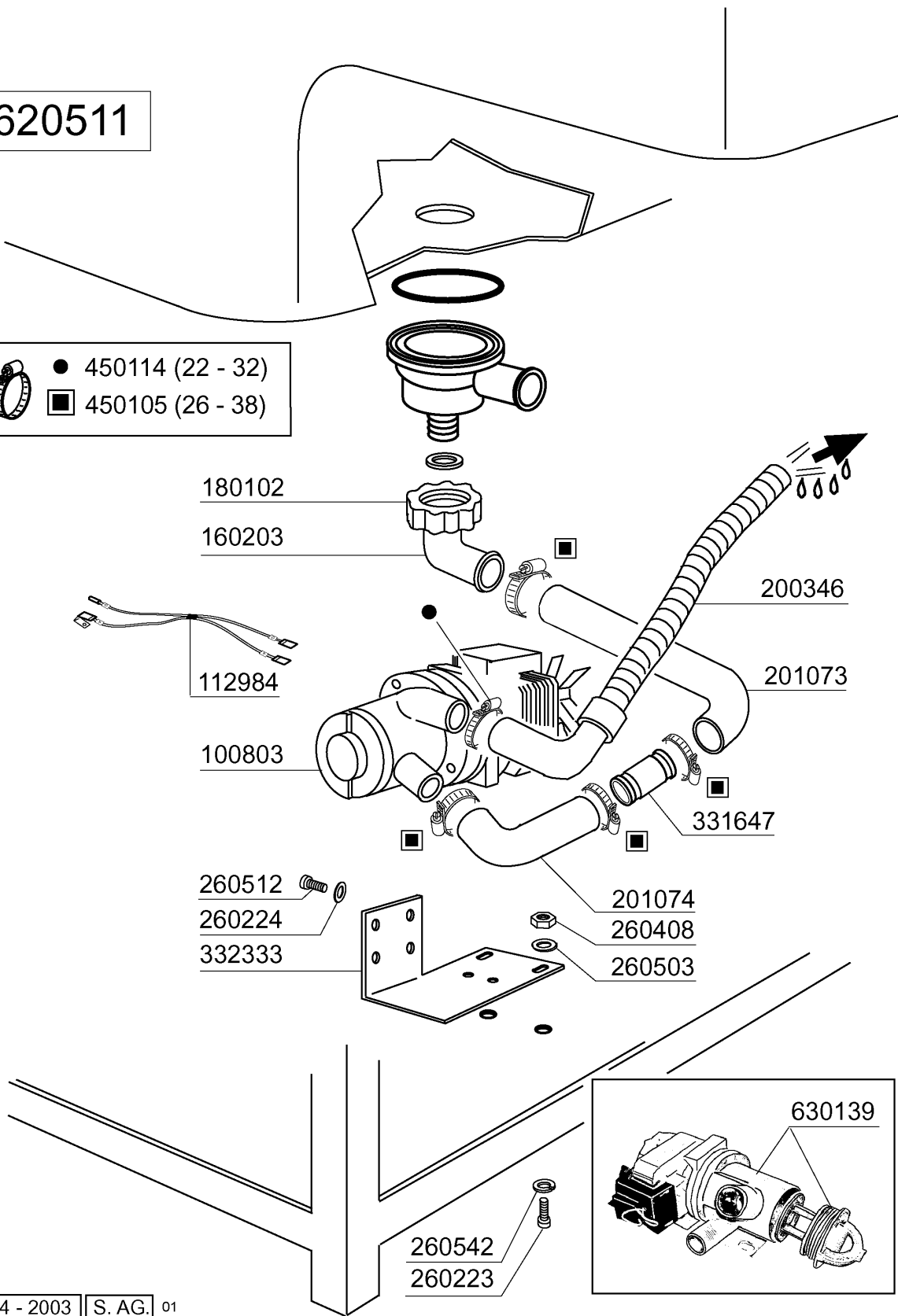

11 - Drain pump

CODE	DESCRIPTION
100803	DRAIN PUMP WITH FILTER 220/50
112984	WIRING FOR DRAIN PUMP F C1000-
160203	ELBOW 1"1/2 N-S-F-C /DRAIN
180102	DRAIN PIPE NUT 1"1/2 F45-55
200346	DRAIN HOSE GLASSWASHER
201073	INLET HOSE LC/CE DRAIN PUMP
201074	HOSE
260223	M5X12 MSH/HD SCREW SPECIAL S/S
260224	TB-SCREW 6X15 B23-10-11-12
260408	S/S NUTS D.12
260503	STAINL.STEEL FLAT WASHER D5 UN
260512	ST/ST GROWER WASHER D6
260542	WASHER D.5
331647	BRACKET
332333	BRACKET FOR DRAIN PUMP
450105	CLAMP FE ZN. 26-38 H=12,2
450114	CLAMP FE ZN.22-32 H=12,2
620511	DRAIN PUMP KIT C1000E-C1300E
630139	DRAIN PUMP VOLUTE WITH FILTER

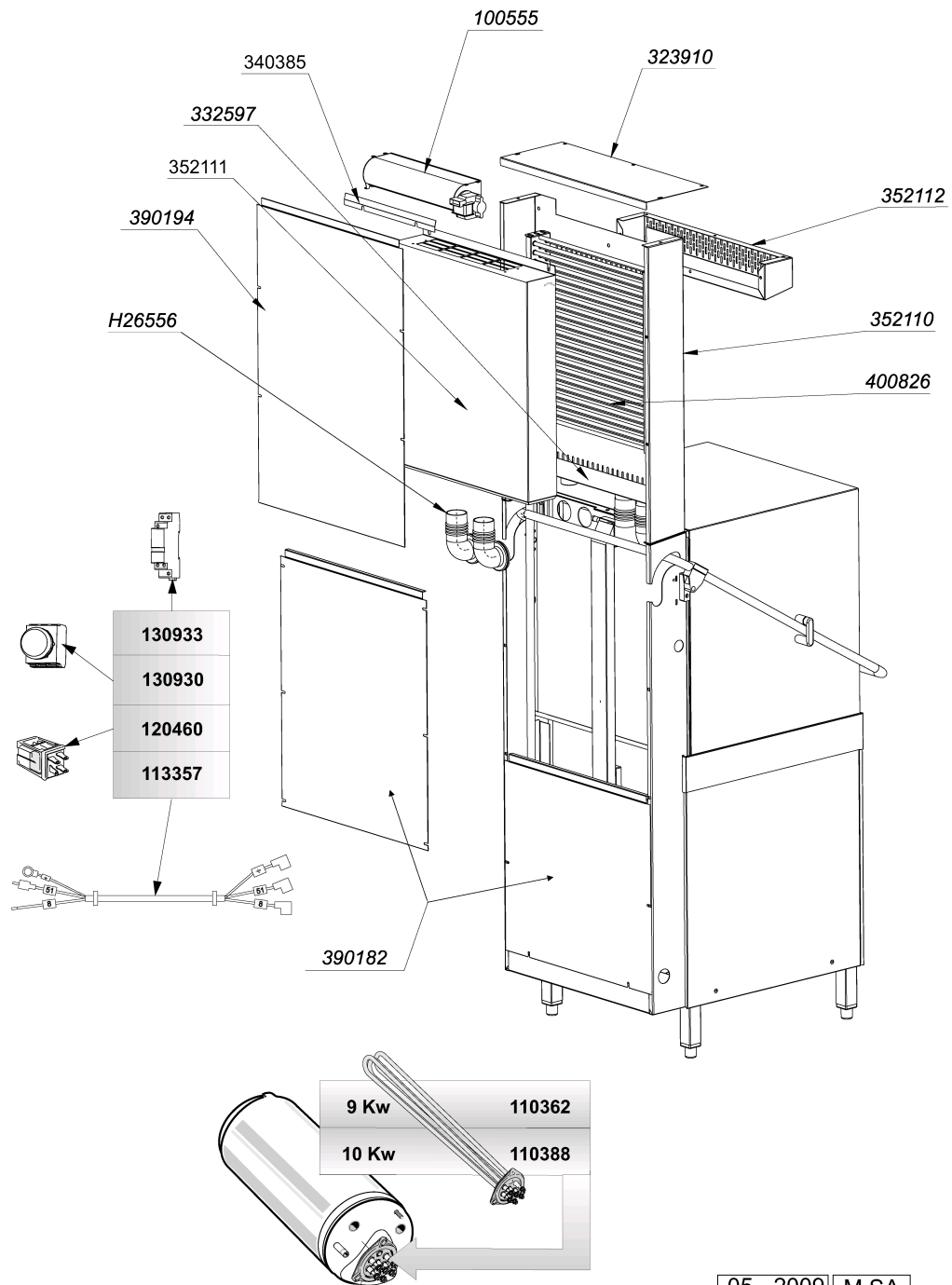

CODE	DESCRIPTION
100555	FAN TGA60/1 360-30
110362	HEAT.ELEMENT 9000W 220/380V
110388	HEAT.ELEMENT 10000W 230/400V
113357	CABLE FOR CRC
120460	RELAY 16A 220V
130930	CONTACT ABB 1NO/1NC 180"
130933	SUPPL. CONTACT NO/NC ABB
323910	CRC UPPER COVER
332597	COLLETTORE ASPIRAZ. CRC C2001
340385	PARATIA VENT."POST" CRC C2001
352110	BACK PANEL
352111	BACK PANEL CRC
352112	FRONT COVER CRC
390182	BACK PANEL
390194	BACK PANEL CRC
400826	CRC BATTERY
H26556	HOSE